

drylin® SHT | linear actuators | Product range

For motorized applications



- Zero-backlash for reduced axial clearance
- Ball bearing lead screw support for high rpm
- Zero-backlash function available for sizes 08 and 12
- Available accessories ► Page 1703
- Lead screw nuts are available separately ► Page 1510
- Available with motor



Order key



Order example

SHT - BB - 12 - AWM

Standard	Ball bearing	Installation Size	Shaft material
----------	--------------	-------------------	----------------

See table below for lead options



Order key

Order example

Options

SHT - 08 - ZB - AWM -

Standard	Installation size	Ball bearing, zero-backlash	Shaft material	Lead
----------	-------------------	-----------------------------	----------------	------

See table below for lead options

Technical data

Part No.	Max. stroke length	Aluminum shaft		Steel shaft		Max. static load capacity	
		Weight	Additional (per 100mm)	Weight	Additional (per 100mm)	axial	radial
		[kg]	[kg]	[kg]	[kg]	[N]	[N]
SHTC-08-ZB	300	0.240	0.05	0.270	0.094	100	360
SHT-08-ZB-AWM- <input type="text"/>	300	0.205	0.05	0.228	0.103	100	400
SHT-12-ZB-AWM- <input type="text"/>	500	1.1	0.1	1.3	0.2	150	600
SHT-BB-12-AWM	500	1.1	0.1	1.3	0.2	350	1,400
SHT-BB-20-AWM	900	3.2	0.3	3.9	0.6	1,000	4,000
SHT-BB-30-AWM	1,000	8.6	0.6	10.9	1.4	1,500	6,000

Lead Options SHT	
Actuator	Leads (T)
-12	TR 10x2
	TR 10x3
	DS 10x12
	DS 10x25
	DS 10x50
	R/L TR 10x2
-20	R/L DS 10x12
	R/L DS 10x25
	R/L DS 10x50
	TR 18x4
	TR 18x8
	DS 18x24
-30	DS 18x40
	DS 18x80
	DS 18x100
	R/L TR 18x4
	R/L DS 18x24
	R/L DS 18x40
-30	R/L DS 18x80
	TR 24x5

Lead Options	
Actuator	Leads (T)
SHTC-08-ZB	6X2P1
	6X2P1
	6.35x5.08
	6.35x12.7
	6.35x25.4

Lead Options	
Actuator	Leads (T)
SHT-12-ZB-AWM	10x12
	10x25
	10x50
	DS R/L 10x12
	DS R/L 10x25
	DS R/L 10x50

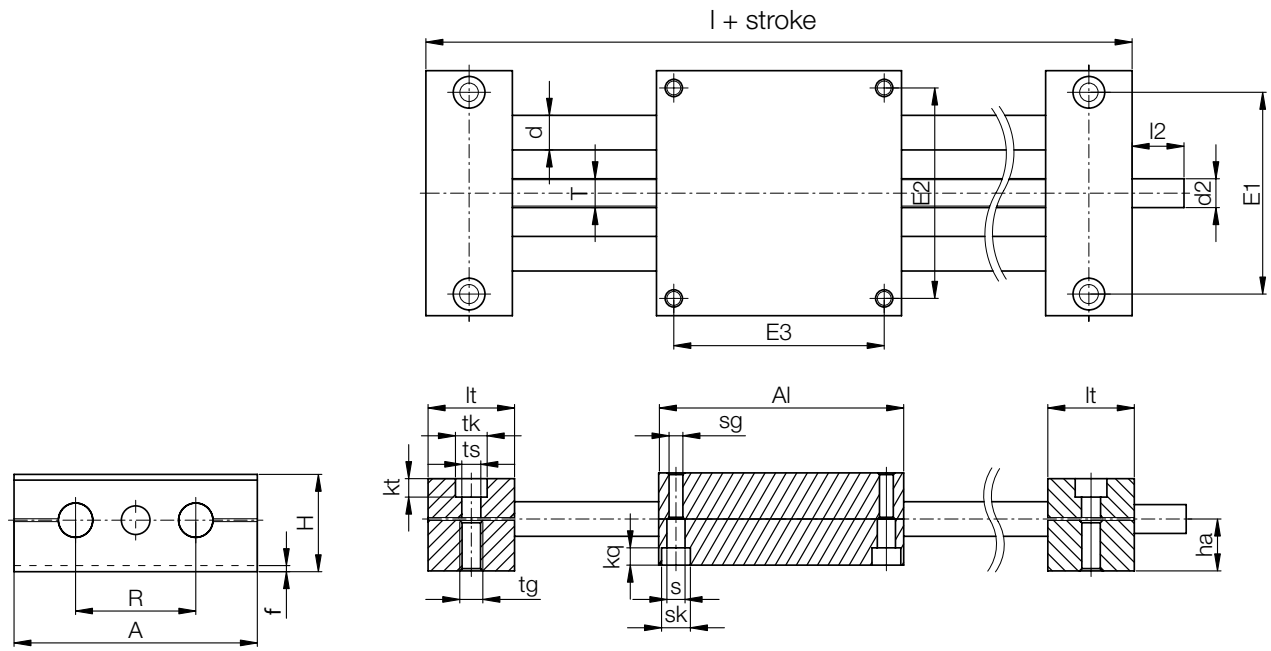

Configure online

► www.igus.com/drylinHTSConfigurator

Dimensions [mm]

Part No.	A	A1	H	E1	E2	E3	l	R	f	lt	tk	ts
	-0.3	-0.3		±0.15	±0.15	±0.15						
SHTC-08-ZB	65	38	23	52	55	26	96	32	1.5	15.5	10	5.5
SHT-08-ZB-AWM- <input type="text"/>	65	65	23	52	55	55	96	32	1.5	15.5	10	5.5
SHT-12-ZB-AWM- <input type="text"/>	85	85	34	70	73	73	145	42	2	30	11	6.6
SHT-BB-12-AWM	85	85	34	70	73	73	145	42	2	30	11	6.6
SHT-BB-20-AWM	130	130	48	108	115	115	202	72	2	36	15	9.0
SHT-BB-30-AWM	180	180	68	150	158	158	280	96	4	50	20	13.5

Part No.	tg	kt	s	sk	sg	kq	d	T (lead)	l2	d2 Standard	ha
		±0.1									
SHTC-08-ZB	M6	7	4.2	8	M5	4.6	8		15	6 / 6.35	13
SHT-08-ZB-AWM- <input type="text"/>	M6	7	4.2	8	M5	4.6	8		15	6.35 ⁹²⁾	13
SHT-12-ZB-AWM- <input type="text"/>	M8	6.4	6.3	10	M6	6.0	12	See table for lead options	17	10x12 ⁹²⁾	18
SHT-BB-12-AWM	M8	6.4	6.3	10	M6	6.0	12		17	Tr10x2 ⁹²⁾	18
SHT-BB-20-AWM	M10	8.6	6.4	11	M8	7.0	20		26	12h9	23
SHT-BB-30-AWM	M16	12.6	11.0	18	M12	10.6	30		38	14h9	36

⁹²⁾ Lead screw end unmachined